

# SAVE MONEY TACKLE CLIMATE CHANGE AND PROTECT WILDLIFE



WITH **THE HUCCLECOTE GREEN GUIDE**



**Hucclecote's Sustainability Festival in May – see inside**

**KEEP THIS GUIDE SAFE FOR FUTURE REFERENCE**

# CONTENTS

Tackling Climate Change .....	3
Saving energy at home .....	4
Biodiversity.....	7
Communication and inspiration.....	14
Travel and transport.....	18
Recycling and waste .....	22
Buy local.....	26
Land use.....	30

## Have we missed anything?

This Guide will be hosted on the Hucclecote Parish Council website where we will add regular updates. If you have any ideas or suggestions for other ways that we can help to tackle Climate Change in the parish, or if you are a local crafts person, grower or business and would like to be listed in the directory, please let us know.

E-mail [hucclecotepc@supanet.com](mailto:hucclecotepc@supanet.com).

## Measuring change

We plan to try to measure the impact this Guide has had among the residents of Hucclecote. We intend to do this via a survey towards the end of 2023.

## Disclaimer

We have striven to make the information in this Guide as timely and accurate as possible. However, Hucclecote Parish Council makes no claims, promises, or guarantees about the accuracy, completeness, or adequacy of the contents of this Guide, and expressly disclaims liability for errors and omissions in the content of the Guide. If readers plan to rely on any information in this document, they are advised to seek their own independent confirmation or advice about the accuracy, completeness, or adequacy of any information contained in the Guide.

# TACKLING CLIMATE CHANGE

## Everyone has a part to play in tackling the challenges resulting from Climate Change.

This Guide has been specifically prepared to highlight some of the things the residents of Hucclecote can do to help. The Guide should also help you to save money as it has lots of tips on how to reduce energy bills.

We all know that tackling Climate Change is urgent; and we all recognise that no one on their own is going to solve all the challenges. But collectively we can make a difference. And, at a local level, that should make Hucclecote a cleaner, safer, and more attractive place for future generations.

This initiative has been launched by Hucclecote Parish Council. Local residents, businesses and councillors got together in 2022, and together they drew up a practical Action Plan that identified a range of initiatives that will be undertaken over the next few years (you can download the Action Plan from the parish website).

These Actions range from ambitious plans to create a new community garden/mini-forest/allotments, through to a series of talks on energy-saving technologies and running publicity campaigns to encourage more people to cycle to work, or lift share.

One of the first things you should see will be the new wildflower beds that will be planted across the parish in 2023. These will be awash with wildflowers by the summer. The flowers not only look wonderful; they'll also help to attract more pollinators to the area.

We also plan to have occasional 'Repair Shop' sessions running later this year - to encourage people to reuse, repair or recycle more. New, larger litter bins are also being installed across the parish soon - these will allow passers-by to pre-sort litter into 'recyclables' or more 'general waste'.

And we want to urge Hucclecote residents to 'buy local' by supporting local businesses, makers, and artists. There is a Directory of local suppliers, growers and crafts people on page 26.

Another ambition we have is to reinforce the protection provided to the best public spaces and countryside in Hucclecote, so we will be seeking to get a number of areas formally designated as 'community assets'.

All this work is being undertaken by volunteers from across the local community.

If you are keen to get involved, we'd be delighted to hear from you. We are especially keen to establish a group of keen younger Climate Change campaigners, and we'd love to hear from volunteers who have good social media skills.

**If you are interested, please contact Sarah at the parish office in Bird Road (she's there every morning during the week). Call in for a chat, telephone her or leave a message on 01452 612485, or email [hucclecotepc@supanet.com](mailto:hucclecotepc@supanet.com).**



Local residents, councillors and businesses discussing the sustainability initiatives they'd like to see undertaken in Hucclecote

# SAVING ENERGY AT HOME

The recent spike in energy prices has hit everyone hard, with average homes now facing typical energy bills of £60 or more a week.

Taking action to reduce the amount of energy you consume makes a lot of sense, as it can significantly reduce these costs. And, of course, if we all consume less energy this reduces our carbon emissions, and ultimately this helps reduce the warming of the planet.

## What should be your priorities?

The answer depends a bit on the sort of home you live in. For example, if it was built in the last ten years or so it should be reasonably well insulated and double glazed. Whereas a home constructed a 100 years ago is likely to have much less effective insulation, and draughts could be a big contributor to the cost of your heating.

If you currently have a modern/efficient gas boiler this is generally a cost-effective way of heating a home and providing your hot water; homes that rely on electricity to provide their heat and hot water tend to cost more to run – a kilowatt hour (kWh) of gas currently costs just over 10p, while a kWh of electricity is typically 34p.

**In most cases your first priorities/biggest savings will come from adjusting the way you currently use your home. For example:**

- Dry your clothes outside or on a rack instead of using a tumble dryer (this can save up to £70 a year)
- Have shorter showers (if you currently have quite long showers, you could save up to £95 a year by limiting them to four minutes)
- Switch off appliances at the plug when they are not in use (potentially saving £65 a year). For example, a games console can cost £25 a year, if not switched off
- Wash your clothes on a low-temperature or eco setting
- Set the temperature thermostat for your hot water to 60°C (this could save you up to £40 a year)
- Reduce the boiler flow temperature to your radiators to 55-60°C (typically this saves the average home more than £100 per year)
- Your thermostats should be set to the lowest comfortable temperature, which for most people is between 18°C and 21°C. If you only have a single thermostat for the whole house, for every degree you increase the temperature, it will increase your heating bill by about 10%. (So if your thermostat is currently set at 22°C and you reduce it to 18°C this could save you – depending on the sort of home you live in – up to £600 a year)
- Check if there are any draughts around your doors and windows (and fix them). Sticky backed foam strips are available from most DIY shops, and they are reasonably easy to install. A simple DIY draught excluder for the bottom of your front door can have a big impact, and make sure the letterbox and key holes have excluders too. If there are small cracks in the walls filling these can also be cost effective. Basic measures like this can save up to £125 a year.
- Drawing your curtains at dusk can reduce the heat lost through your windows by 17% (saving up to £50 a year). Upgrading to thermal curtains that fit your windows properly can reduce the heat lost in your home by up to 25%.
- Check the amount of insulation in your loft. Ideally you want at least 250mm, though you could increase this to 300mm. Mineral wool insulation is relatively cheap and easy to install so it might be worth upgrading.

*Note – the savings indicated here are based on averages and therefore the savings you actually achieve may be less depending on size and type of home you live in, and your current energy usage*

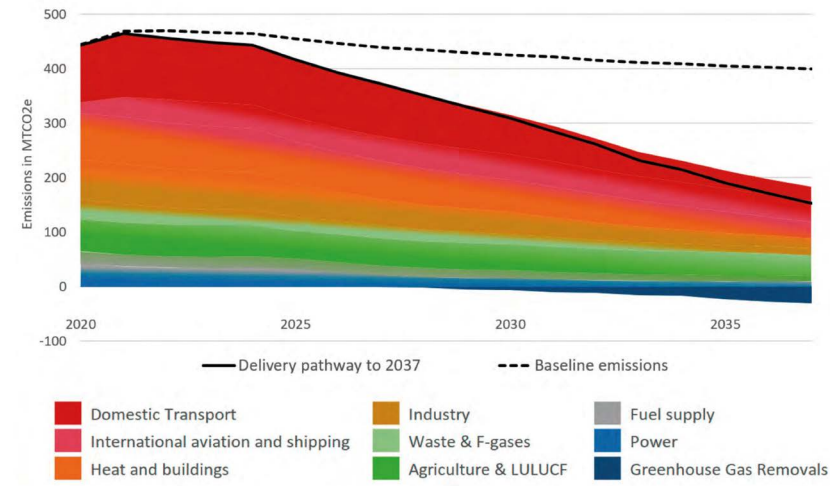

This chart shows the Government's target reduction in carbon emissions over the next 15 years. The orange band in the middle is the heat from buildings. If you look closely you can see that it's one of the widest bands at present, and by the time we get to 2037 in needs to be a fraction of the current level. By 2050 the aim is to have reduced it even further.

To put this into perspective, the average household currently generates about 2,700 kg of carbon dioxide (CO<sub>2</sub>) from space heating and hot water per year. By 2050, we need to reduce this to just 140 kg per household.

## SAVE ENERGY WHEN COOKING



- An electric fan oven costs about £1 an hour to run while a slow cooker is just 5p an hour. Air fryers cost roughly 30p an hour
- A microwave costs about 2p for five minutes. Electric hobs cost 17p per quarter of an hour – so it's much more expensive to boil veg in a pan that it would be to cook in a microwave
- Use residual heat (the heat in an oven after it's turned off) to warm plates, bread rolls etc



## RUNNING COSTS OF APPLIANCES



**How much energy do things use and cost?**

One load of washing	0.5kWh	17p
One load in tumble dryer	3kWh	£1.02
One dishwasher cycle	0.9kWh	31p
Boil FULL kettle (7 cups)	0.2kWh	7p
Fridge/freezer for a year	292kWh	£99.28
Watch/leave 60" TV on standby for a year	286kWh	£97.24



## CUT BOILER FLOW TEMPERATURE



If you have a combi-boiler, you can control the temperature of the water to your radiators. The 'default' setting is usually around 80°C but it could be dialled back to say 55-60°C. This should reduce your gas consumption by 9-12%.

Find out if your boiler can be adjusted and how to do it here: <https://moneysavingboilerchallenge.com>



## ADJUST HOT TAP TEMPERATURE



If you have a combi-boiler or a heating system with a separate hot water cylinder, you can turn down the temperature thermostat at 60°C so that water is not heated needlessly. This could save about £40 a year.

There's a video to explain how to do it here: <https://www.youtube.com/watch?v=jcU6Bjx6dw>



## LAUNDRY TIPS



- Washing clothes at 30°C uses 40% less electricity.
- Clothes like jeans can often be worn many times without washing – they'll last longer too.
- Synthetic garments like fleece, nylon, acrylic etc can shed thousands of microscopic plastic fibres that then enter the environment.
- Use eco-friendly detergents, like Ecover or soap nuts – the fruit of a Nepalese tree. The shells contain a natural soap so you can just chuck them in the compost.
- Fill up the washing machine – one full load uses less energy and water than two half loads.



# BIODIVERSITY

Huge new developments, roads, traffic, and industrialised farming across the UK have caused a big decline in the animals we know and love like songbirds, hedgehogs and frogs.

And alongside this there has been a big reduction in the number of plants, insects, and invertebrates that these bigger animals depend on. But we can all do lots to help.

For example, if all of Britain's gardens were joined together, they would cover an area larger than some national parks, so how we maintain and manage our gardens can make a big difference.

### Top Gardening Tips

- **Go easy on the weeding** – leave a few patches to grow long and a bit unruly. Most plants we regard as weeds are crucial to wild animals e.g. nettles are food for many butterfly and moth larvae, while the energy-rich ivy berries are one of the most important winter foods for our birds.
- Instead of 'dead-heading', **leave seed pods** over winter to provide a great habitat for overwintering invertebrates.
- **'No Mow May'**. Let your lawn grow through the month of May (or even longer!), to give wildflowers a chance to produce nectar to feed pollinators.
- **Put up a bird box**. Make sure it is facing north or east, to keep it away from sun, rain, and wind. Full instructions on how to make one yourself are provided on page 10.
- **Make your own compost**. There is lots of information available online to help with this simple and fulfilling task – see page 12.
- **If you buy compost, make sure it is peat-free**. Peat from our moorlands is an important habitat and a huge store of carbon. When dug up for compost this stored carbon is lost to the atmosphere, contributing to Climate Change.
- **Form a pile of logs and sticks, to provide shelter and food for beetles, invertebrates, etc**. But avoid cherry wood as it can encourage unwanted fungi. On page 11 there's guidance on how to make your own bug hotel.
- **Create a pond** (even if there's only enough space to sink a washing up bowl). Ponds almost instantly attract life. Ensure one side has plenty of rocks or sticks so that, if an animal falls in, it can escape. Keep it free of fish – they eat frogspawn and tadpoles!
- **Use natural and non-toxic alternatives to herbicides and pesticides**. Try biological controls such as nematodes – tiny creatures that eat many pests. They can be bought online or in garden centres. Encourage natural predators such as ladybirds, hedgehogs and birds, and use physical controls such as netting and wool pellets to discourage slugs. There is a wealth of information about each specific problem online.
- **Save money by collecting rainwater in water butts** – rainwater is also better for plants and wildlife than chlorinated tap water.
- **Scything** is growing in popularity and is more environmentally friendly than petrol lawnmowers or strimmers. It will also keep you fit. Find out more at [www.scytheassociation.org](http://www.scytheassociation.org)
- **Are you looking for an allotment but can't find one?** Or do you have a garden or land you aren't using or can't take care of? Would you be interested in letting local people use it to grow vegetables in return for a share of the harvest? If so, contact the Parish Council and we'll try to match you up.





## Trees, woodlands and wildflowers

Trees are important in helping to mitigate Climate Change by storing carbon. They're also a keystone for biodiversity. For example, oak trees support at least 2,300 other species.

Unfortunately, Climate Change is intensifying stress on trees. A warmer, wetter climate will enable new pests, diseases, and invasive species to thrive and spread. Sadly, we already have Ash Dieback in Hucclecote. This disease means many of our trees are dying and having to be removed from roadsides and footpaths for safety reasons.

So, we need to do all we can to learn how to look after our trees and replace those that die. Skills and knowledge that were once commonplace but now scarce need to be re-learned or supported.

If you do have space to plant trees always remember – the right tree in the right place and for the right reason. Ideally only plant native trees or shrubs. If in doubt, talk to a professional and always source local trees.

The Parish Council, with support from the Benefact Group and the Woodland Trust has already planted hundreds of trees in various locations across the area. And we have an ambitious plan to create a 'Tiny Forest' on open space near Pineholt Village Hall. This will involve planting around 600 native trees, around an open air 'classroom' that can be used by local schools.

Trees aren't the only natural way of storing carbon. Other habitats, such as grassland meadows and wetlands, are also important carbon stores, and very important for biodiversity.

## Leaving road verges long for wildlife

You may have noticed that roadside verges are being mown a lot less (where this is safe for road users). The result has been a huge increase in insect and plant species, including many colourful wildflowers – instead of short green grass, which may look 'tidier' but supports vastly less life.

## Dedicated wildflower planting

The Parish Council is creating ten new swathes of wildflowers during the spring and summer of 2023. And later in the year we will be organising a volunteering session so that local people can help us collect wildflower seeds. These seeds can be used to boost the beds in future years and any spare seeds will be available for residents to plant in their own gardens.

Most front or back gardens can support an area of wildflowers. This website has lots of guidance on how to prepare and plant your own wildflower area:

<https://www.wildlifetrusts.org/actions/how-grow-wild-patch-or-mini-meadow>.

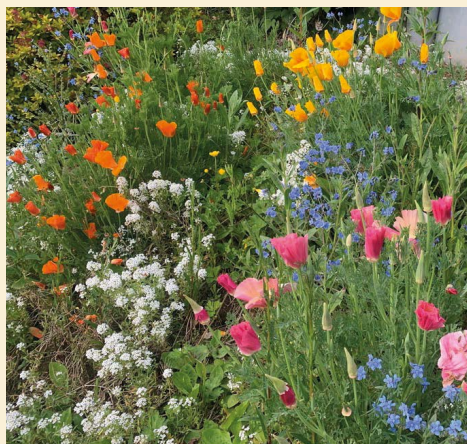

## Help the hedgehogs

Hedgehog numbers across the UK have fallen from more than 30 million in the 1970s to less than one million today.

One of the main problems is that many gardens have been paved over or covered in astroturf; or they have fencing that prevents access. Hedgehogs can travel over a mile each night in search of food.

## Top Tips

- Make sure your fence has at least one 15x15cm gap so hedgehogs can get in and out.
- Don't use slug pellets. These can poison animals that eat slugs, such as hedgehogs and song thrushes. Try less harmful methods such as wool pellets, eggshells, copper wire or water trays (moats).
- Use humane (catch and release) rat traps instead of rat poison. Tests on dead hedgehogs show that many of them have consumed rat poison.
- Do not offer hedgehogs milk or bread as it will make them sick – they are lactose intolerant. It's much better to give them wet or dry cat food.

Hedgehogs are nocturnal. If you find one in daylight hours there may be something wrong with it – please call **Brockworth Hedgehog Rescue** on 07789 268296.



## Wildlife in trouble?

If you find an injured or sick animal, please contact the **Noah's Ark Rescue** for help and advice. Its local volunteers can help to catch and treat wildlife or stray pets and can transport to local specialist rescue centres. Visit [www.noahsarkrescue.org.uk](http://www.noahsarkrescue.org.uk) or call 079712 489168.

## Got a bee problem?

Swarms of bees are most likely encountered from May to July. Local beekeepers can come out to collect them and remove them to safety, so the bees can carry on doing their important work. The **Gloucestershire Beekeepers Association's** local Swarm co-ordinator is Mike Forster on 01452 478473.

## Feel like Volunteering?

There are many ways you can volunteer to help tackle biodiversity issues locally. For example, the **Horsbere Brook Nature Reserve** and the **Hucclecote Meadows Site of Special Scientific Interest** runs regular sessions planting trees, improving hedges, seeding wildflowers and much more. The Friends of Horsbere Brook and the Hucclecote Meadows Facebook pages are co-ordinated by the Countryside Team at Gloucester City Council. Call 01452 303 206 or email them at [countryside@gloucester.gov.uk](mailto:countryside@gloucester.gov.uk).

If you want to support the **Chosen Hill Friends** group that helps maintain the paths and stiles Linda Kirkhope is the main contact and her email is [fchill@hotmail.co.uk](mailto:fchill@hotmail.co.uk).

The Parish Council also organises regular litter picking, path clearing and tree planting sessions so contact the parish office or keep an eye on the council's website or Facebook page for these opportunities.

# Build your own bird box...

# ...or bug hotel

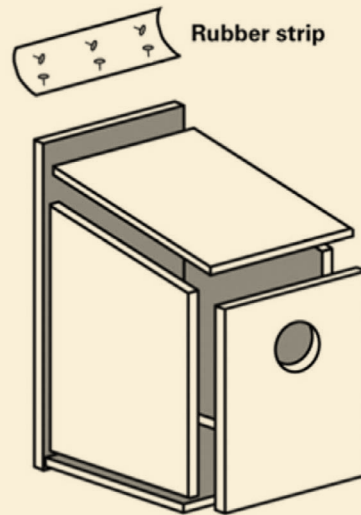
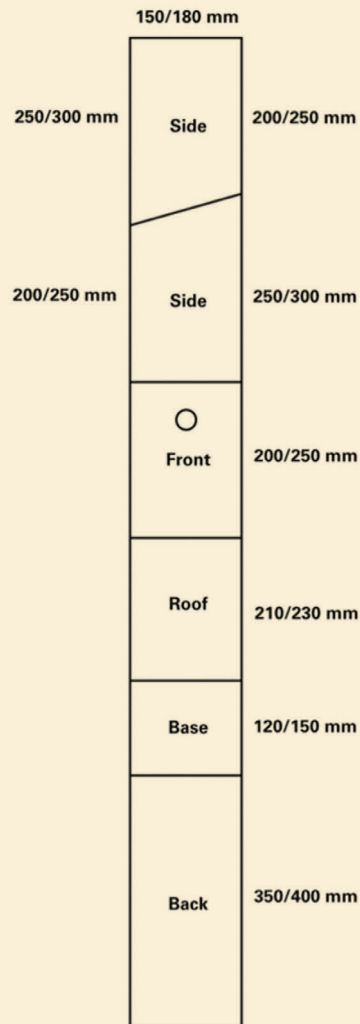

## Bird box instructions

Choose a plank about 150mm wide and 15mm thick. Use the diagram to help and cut the different sections for the box using a saw.

The inside of the box must be at least 100mm square, and the bottom of the entrance hole must be at least 125mm from the floor. If it is less, young birds might be scooped out by a cat.

Use galvanised nails or screws. The inside front surface should be rough – this will help the young birds to clamber up. A drainage hole in the base will also help to stop the box getting damp inside.

Hinge the lid with a strip of leather or rubber (an old piece of bicycle inner tube would do). Do not nail the lid down (because you will need to clean out the box in autumn). Instead, use a catch to keep it closed.

The entrance hole size depends on the type of bird you want to attract:

- 25mm for coal tits, marsh tits and blue tits
- 28mm for great tits and tree sparrows
- 32mm for nuthatches and house sparrows
- A starling box needs to be 25-30% larger with an entrance 45mm across
- If you remove the top half of the front panel, the box might attract robins, pied wagtails or wrens.
- Spotted flycatchers prefer an even shallower, open-fronted box.

Softwood boxes (such as pine) can be treated with water-based wood preservatives, such as Fenceguard or Sadolin: apply only to the outside of the box, and not around the entrance hole. Whatever you use, make sure the box dries and airs thoroughly before putting it up.

(Children should ask an adult to help them, as you will need to use sharp tools and do not use chemicals like wood preservatives without an adult).

There is more advice on bird boxes at the Royal Society for the Protection of Birds website – [www.rspb.org.uk](http://www.rspb.org.uk).

## Bug hotel instructions

- Cut a plank of wood into five pieces. Three pieces should be the same size – this will form the rectangular frame that supports the roof.
- Drill guide holes and screw the frame together.
- Load the frame with canes, reeds and stems, packing them tightly.
- Fix your bee hotel facing south, in a sunny spot that is sheltered from the rain.



# Composting for beginners

**At present about ten per cent of UK homes set aside their food waste for collection by their local authority, and just three per cent currently compost their own food and garden waste. The vast majority of people they just lob their food scraps into their main bin.**

The average home generates around half a tonne of food scraps each year, which means millions of tonnes of food scraps are going to landfill. When food waste breaks down in landfill it generates methane; and methane is 25 times more harmful than carbon dioxide because it can trap heat within the atmosphere.

Home composting isn't difficult, and it doesn't generate methane. And if you do it correctly, you'll be turning your food scraps into rich compost that would otherwise cost you a small fortune from a garden centre.

## Size matters

Clearly a big garden is likely to require a more substantial composting facility than a small one; but just about any modest garden can support a compost bin of some sort.

If you have a larger garden you might want two or three simple bins alongside each other, so that you can transfer the contents from one to the other – to speed the composting process along.

For a smaller garden a single, quite small bin will suffice.

## Different types of bin

There are three main types:

- **Off the shelf plastic bins**, available from most DIY stores or garden centres

- **Timber bins** (often available as a flat pack kit) that slot together. Some of these can look quite attractive (for example you can get ones that look like little beehives); simple DIY low-cost versions can also be made from wooden pallets
- **Rotating hot bins** – these are more elaborate and look a bit like a barrel held in a frame. By spinning the compost inside the barrel the compost rots down very quickly.

You can, of course, just create a pile of compost in your garden or on your allotment.

Most bins work best on a solid/impermeable base – something like concrete or tiles...then mice will find it much harder get in, and it's easier to shovel the compost out.

## Plan your food scrap collection system

If you don't have a place to put food scraps when you're in the middle of chopping fruit and veg, they'll probably end up in the general waste bin.

Pick your container and have it sitting somewhere you'll see and use it. A proper compost collecting bin is great because it has filtered air flow, which keeps flies out, but also prevents your fruit from fermenting. Fermentation won't start immediately though, so if you use a container with a tight lid, just make sure you empty your scraps every few days.

## Top tips for making great compost

- Cut or break up compost ingredients into small pieces before adding them to the compost bin. This will help to speed up the process.
  - Make sure the compost is full of air by turning it and mixing it regularly.
  - If the compost feels dry add water or some 'greens' such as grass clippings or vegetable peelings.
  - Make sure there is a mixture of 'greens' and 'browns' in your compost heap – 'greens' are things like grass clippings, dead flower heads, annual weeds with no seed heads, uncooked kitchen waste, fruit and vegetables, leafy plants. 'Browns' are things like twiggy prunings such as hedge clippings or small twigs from a bush/shrub, woodchip, leaves, plant stems, paper (including shredded paper), card and straw.
  - Compost is all about balance. If you add too many food scraps or 'green' material vs. 'brown' material, it will smell.
- The opposite is true as well. If your pile isn't decomposing, add more food scraps or 'green' material.
- Make sure the pile stays moist, but not too wet (it should feel like a damp sponge). Add water if too dry. To prevent the compost becoming too soggy, cover with a tarpaulin, or add extra shredded paper. Having a lid on the compost will insulate it and allow more accurate control of the moisture content.
  - Do not add perennial weeds that have fleshy roots as they may survive and regrow e.g. dandelions. Don't forget to remove produce stickers from any food scraps that go in.
  - If the compost is too wet, mix in some crunched up newspaper, paper towels, cardboard or twiggy prunings to restore a good green/brown balance.
  - Do not add cooked food such as meat or dairy produce as this will attract vermin.

## How to make a paper plant pot

Making your own paper pots is not only eco-friendly, it will save you money too. They are ideal for growing small plants that are then planted out in the garden, as the pots are completely biodegradable. When the plants are ready to go outdoors, the whole pot can simply be planted into the soil.

All you need to get started is a pile of newspaper and some cylindrical objects to act as moulds. Try using a bottle and wrapping strips of paper tightly around it, several times, before folding over the base and sliding the paper off. There are also simple, wooden pot-making kits available to buy.

### Step 1

Choose moulds of different sizes in order to make a range of pots suitable for all your seed sowing and plant raising activities.

### Step 2

Cut strips of newspaper wide enough to fold halfway across the mould base, and roll the paper round to make 4-6 layers per pot.

### Step 3

Wrap tightly to create firm pots, then start folding the paper over the base so there is no gap for any compost to fall through.

### Step 4

Wooden kits have a crimping block that helps create a crease to hold paper rigid, or just push the base firmly onto a flat surface.

### Step 5

Carefully slide the paper pot from the mould. Stand pots in a seed tray, ready for sowing.



# COMMUNICATION & INSPIRATION



When our Action Group was working out what it felt we needed to concentrate on there was a consensus that residents wanted to find out more about key issues, and they needed simple, practical advice.

This Guide forms part of this initiative. But it was also felt that residents would be really interested in a range of talks, demonstrations, study visits or workshop sessions on a broad range of topics associated with Climate Change.

We are therefore organising a 'Sustainability Festival' that will be staged in Hucclecote this May. The activities will be aimed at the specific needs and interests of local people.

Local businesses and other organisations are helping us stage these events.

On page 15 we explain how you can register to attend the events, and there are profiles of the main speakers. And overleaf you'll find the full programme.

**Entrance to all the events is free**, but we would like people to register beforehand so that we have a reasonable idea of the number of attendees we will be attracting.

Lots of local environmental organisations are involved in the various events, and we are grateful for their support and the information they are providing.

## HOW TO RESERVE YOUR PLACE – ALL EVENTS ARE FREE

Anyone can attend any of the events during the Festival, though some of the venues are quite small, in which case places may be limited. Some events probably won't be suited to very young people. To secure your place(s) please go to the Eventbrite website ([www.eventbrite.com](http://www.eventbrite.com)) and search its database using the titles of the talks (see overleaf). Alternatively you can just search for 'Hucclecote Sustainability Festival' - this should bring up a list of all the main events that will be taking place during the week.

You will need to key in a few details – name and contact details – and the website should then generate a ticket which you can store on your phone, or print out. We will not use your details for any marketing activities. For some events – like the Wildlife Talk and Family Walk on May 7, and the Litter Picking session on 8 May you don't really need to register – just pitch up at the venue at the appointed time.

**eventbrite**

### Speakers

**Sandy Hore-Ruthven MBE** is the Chief Executive of the Severn Wye Energy Agency. Before this he was the CEO of the Creative Youth Network, the largest charity provider of youth services in the Southwest. As a founding member of the Bristol Mayor's 'One City' Board, Sandy initiated its plans to reach Net Zero by 2030 and worked with businesses, charities, communities, and local authorities to tackle a range of environmental issues.



**Maggi Brown** has been involved in horticulture for nearly 40 years. She joined the advisory team at Ryton Organic Gardens (now re-named Garden Organic) in the 1990's where she rose through the ranks to become the Head of Education and wrote the first organic gardening book specifically for schools. Maggi has been involved with the Chelsea Flower Show and has run numerous courses for the Royal Horticultural Society, and she has been advising people and giving talks about composting for many years.



**Dr Peter Boait** is a director and Chair of Gloucestershire Community Energy Co-op, which installs community-funded photo voltaic (solar panel) systems. He is also a visiting Research Fellow of the Institute of Energy and Sustainable Development at De Montfort University and has been involved in renewable energy projects since 2002.

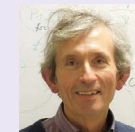

**Richard Lawrence** is Gloucester City Council's Senior Countryside Ranger. He and his team are responsible for the management of 240 hectares of nature reserve, including Hucclecote Meadows Site of Special Scientific Interest (SSSI), and the Horsbere Brook Nature Reserve – both of which are in Hucclecote Parish.



**David Drew** is currently a county councillor, and he was formerly the MP for Stroud. When in Parliament he was the Shadow Minister for the Environment Food and Rural Affairs. He has a keen interest in transportation issues, particularly public transport, and is a committed cyclist. He is an active member of the Campaign for the Protection of Rural England and the Gloucestershire Wildlife Trust.



**Jan Broadway** chairs the Hucclecote Horticultural Society. She has been growing fruit and vegetables since moving to Gloucester and buying her first house in 1985. The lawn of her current house has been covered by raised beds and she has had an allotment at Saintbridge since 2015. She describes herself as a pale green organic gardener. Jan is also interested in the history of gardening, on which she has given talks and published articles.

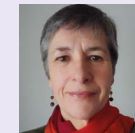



# THE HUCCLECOTE SUSTAINABILITY FESTIVAL PROGRAMME

All events are **FREE**  
See page 15 to book your place

<p><b>Wednesday May 3 at 7pm</b></p> <p><b>Formal Launch of the Festival</b> at the Benefact Group offices (Cotswold Suite), on the Business Park. Followed by a talk from <b>Energy efficiency experts Severn Wye</b> who will outline practical, affordable steps to reduce your home energy bills – The speaker will hopefully be Severn Wye’s CEO Sandy Hore-Ruthven.</p>	 <p>Sandy Hore-Ruthven</p>
<p><b>Thursday May 4 at 7pm</b></p> <p><b>Composting for beginners – everything you need to know about the different ways of composting your leftovers and garden waste</b> – Coopers Edge Community Centre. This talk will be led by <b>Maggi Brown</b> on behalf of the Gloucestershire Master Composters, a local voluntary organisation that promotes home composting.</p>	 <p>Maggi Brown</p>
<p><b>Friday May 5 at 7pm</b></p> <p><b>Solar panel systems – benefits, costs and challenges</b> – this talk will take place at Pineholt Village Hall and be presented by <b>Dr Peter Boait</b>, the chair of the Gloucestershire Community Energy Co-op.</p>	 <p>Dr Peter Boait</p>
<p><b>Saturday May 6 – 10am to 1pm</b></p> <p><b>Meet your local growers and makers at our ‘Pop-up Market’</b> in the car park outside Pineholt Village Hall.</p>	
<p><b>Sunday May 7 at 3pm</b></p> <p><b>A wildlife talk and a self-guided family walk around Hucclecote Meadows</b> – the City Council’s Senior Countryside Ranger, <b>Richard Lawrence</b>, will introduce this self-guided walk. Bring the whole family and discover the wildlife that’s right on Hucclecote’s doorstep. Meet at the entrance to the Meadows, off Lobley’s Drive. An organisation that inspires people to support and volunteer to help their local Wildlife Trusts will also be in attendance.</p>	 <p>Richard Lawrence</p>
<p><b>Monday May 8 - 10am to noon</b></p> <p><b>Join our parish-wide litter picking session organised by the Hucclecote Wombles.</b> On this day the Coronation Festival organisers are encouraging people to volunteer for their community. Meet at Pineholt Village Hall and wear good shoes (and ideally gardening gloves). We will supply litter picking tongs and bags.</p>	
<p><b>Monday May 8 at 3pm</b></p> <p><b>Heat pumps – are they right for you? Visit two local installations, find out the challenges, the costs, and the potential payback.</b> The event will take place on Chosen Hill – one installation is a Ground Source Heat Pump, the other is an Air Source heat Pump. Limited to 10 people – register in advance and details of the locations will be forwarded to you nearer the time.</p>	
<p><b>Tuesday May 9 at 6pm (talk starts at 7pm)</b></p> <p><b>How can Hucclecote residents reduce their transport costs and greenhouse emissions?</b> Local bike shop Slam 69 will be at Pineholt Village Hall from 6pm to help residents check/service their bikes. The Crime Prevention team will also be there to provide free security marking. Former Shadow Environment spokesman and passionate green travel campaigner <b>David Drew</b> will explore solutions like lift sharing schemes, grants to encourage people to cycle to work and ‘No Car’ days. His talk will start at 7pm. Bring the family, dig out your bikes from the shed and (weather permitting) there’ll be a community bike ride afterwards.</p>	 <p>David Drew</p>
<p><b>Wednesday May 10 at 7pm</b></p> <p><b>A beginner’s guide to growing veg and soft fruit</b> – a talk and Q&amp;A session organised by the Hucclecote Horticultural Society at Pineholt Village Hall. The session will be led by <b>Jan Broadway</b>, the chair of HHC.</p>	 <p>Jan Broadway</p>

# TRAVEL & TRANSPORT

For most families transport makes up a very big portion of their total household's carbon footprint. The pie chart below suggests that 27% of the average UK household's carbon emissions are down to transport.

A recent study reckons that in Gloucestershire the figure is currently 34%.

Every one of us is responsible, on average, for about three tons of CO<sub>2</sub> a year being pumped into the atmosphere. So, it's a big contributor to Climate Change, and it's an area where we can all make a significant impact.

Most people generate about two thirds of their transport carbon footprint from the use of their cars or public transport; the other third is down to air travel. So, on the next few pages we've concentrated on car use, and what you can do to make an impact. And on page 21 we've listed ten things you can do to reduce the impact if you do have to fly.

Average UK person's Greenhouse Gas Footprint: 12.7tonnes CO<sub>2</sub>e per year

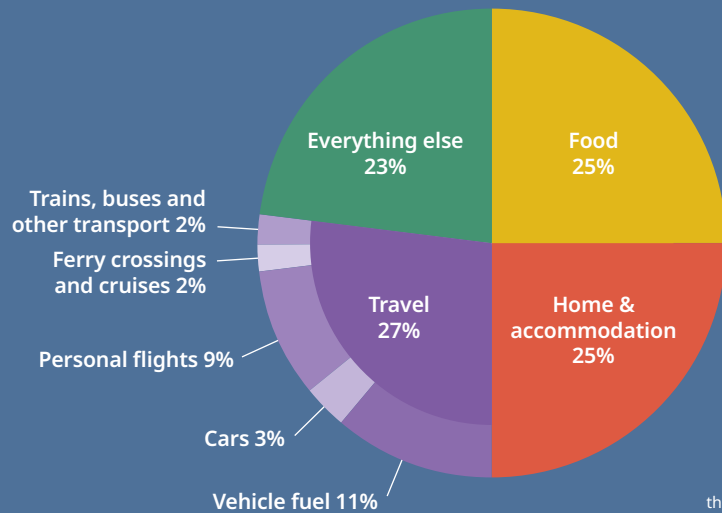

Source: 'How bad are bananas – the carbon footprint of everything'

## Lift sharing

The average worker drives more than 4,000 miles a year commuting to and from work. The fuel alone for this adds up to more than £700 a year, and with all the running costs and other motoring overheads the total works out at closer to £2,000.

But if you were able to share your car with fellow co-workers this could save you a small fortune. On average you could be more than £1,000 a year better off.

There are other benefits too – for example you would be helping to reduce global CO<sub>2</sub> emissions. You'd also get to meet new work colleagues, your commute would be more sociable, and if you share the driving you also reduce your commuting stress. Many employers encourage their staff to lift share, so check at work if there are already systems to help staff team-up.



If you can't find someone to share your commute at your workplace there are more than 2,500 Gloucestershire drivers involved in the wider lift-sharing scheme managed by the Car Share Gloucestershire website. All you have to do is enter your journey details, they'll match you up with everyone else going your way. [www.liftshare.com/uk/community/gloucestershire](http://www.liftshare.com/uk/community/gloucestershire)

## Try Going Car Free for a day

Many major towns and cities now organise regular Car Free Days, when residents are encouraged to leave their cars at home and either walk, cycle or take public transport.

We will be promoting **World Car Free Day** on **Friday 22nd September**, when we will ask Hucclecote residents to give it a go. It is a worldwide initiative to encourage motorists to take a break from driving and to explore alternative options.

But there's nothing to stop you experimenting with the concept before

then. And if you find it's not as difficult as you may have thought, you could make a commitment to Go Car Free once a month, or perhaps even once a week.

Reducing the number of cars on our roads has a significant impact on air quality, and can also bolster local economies as more commuters are likely to visit shops and small businesses when they are not driving. Recent research published by the Clean Cities Campaign suggested around 60% of people believe leaving their cars at home one day per week is a good idea.



## The cycle to work scheme cuts the cost of buying a bike

You could save 32-47% of the cost of a bicycle and accessories (including e-bikes and cargo bikes) with the Cycle to Work scheme.

Your employer needs to sign up, and once its approved you pay nothing upfront (the

payments are taken tax efficiently from your salary by your employer). More than a million people have benefitted from the scheme so far.

Find out more here – [www.cyclescheme.co.uk/how-it-works](http://www.cyclescheme.co.uk/how-it-works)

## Learn to Scoot safely

Zwings, the company that operates the e-scooters locally, has agreed to run a free e-scooter training course to help people stay safe on Hucclecote's roads.

The course is likely to cover:

- The rules of the scheme and e-scooter basics
- A first scooter ride
- Guidance on passing vehicles and negotiating junctions

Attendees must hold a provisional or full driving licence, and must be 16 or older.

The course is expected to take place at Pineholt Village Hall.

At the time of going to press the date had not been confirmed, so keep an eye on the Parish website and Facebook page or email the parish office if you'd like to attend – [hucclecotepc@supanet.com](mailto:hucclecotepc@supanet.com)



## Discover eco-driving, and make your fuel go further

Depending on the current driving style of drivers, an eco-driving course can typically result in a fuel reduction of 10-20%; and as well as saving money eco-driving also reduces your carbon footprint. Here are six simple tips:

### 1. Check your tyre pressure

Under inflated tyres add to rolling resistance and increase fuel consumption by up to 5%.

### 2. Remove excess weight

Any extra weight will require the engine to work harder to move it, and that effort uses fuel. For an average car, every extra 15 kg of weight reduces your fuel economy by around 1%.

### 3. Rein in your 'revs'

Choosing the 'wrong' gear reduces efficiency and wastes energy. Eco-driving techniques encourage you to 'change up' to the next gear more quickly than previously recommended.

### 4. Ride the 'green wave'

More energy is required to accelerate a vehicle than to maintain a steady speed. In most cars, energy is also 'wasted' during breaking (fuel energy used for acceleration ends up as heat during braking). It therefore pays (economically and environmentally) to avoid unnecessary accelerations, decelerations, starts and stops.

### 5. Reduce your top speed

The most fuel-efficient speed is usually around 45-50 mph (in the highest gear). Increasing your speed to 60 mph typically reduces fuel economy by 6%; upping your speed to 70 mph, reduces fuel-efficiency by a further 9%.

### 6. Use air-con sparingly

Air-conditioning units are highly fuel thirsty and can increase a vehicle's overall fuel use, and hence CO<sub>2</sub> emissions, by 20%. If you have to use it, save it for higher speeds, and open windows at lower speeds.

## Ten Tips to reduce the climate impact of flying

### 1. Pack light

The more you pack, the heavier the aircraft – and the more fuel required. Rent bulky gear at your destination instead of packing it, use miniature refillable containers for toiletries and pack versatile items that can be re-worn.

### 2. Opt for economy

Business and first-class seating takes up more space and weight, so more fuel is required per passenger (first-class tickets account for, on average, four times the emissions of an economy seat). So, book economy, even if you can afford to travel in style!

### 3. For shorter trips don't wing it at all

The bulk of a plane's emissions occur during take-off and landing, meaning that mile for mile, shorter flights have a greater carbon footprint. For flights under three hours, investigate the alternatives.

### 4. Go public

When you arrive, rather than hiring a car use public transport to and from the airport and at your destination. If you're able to, walk or cycle as much as possible.

### 5. Fly direct

Some people choose routes with multiple stopovers to save money. However, with just one fuel-guzzling take-off and one landing, flying direct is another way to ensure you're minimising your impact.

### 6. Find the airlines doing their bit for the environment

While you're comparing airline prices, compare the company's eco-credentials too. Airlines with newer fleets are generally more fuel efficient too.

### 7. Be greener in your search

Some third-party flight booking sites now display less-harmful flight options. For example, Skyscanner looks at the aircraft, flight distance, seating capacity and cruising time – all aspects that influence their impact – and marks the eco-friendly options with a green leaf. Glooby even allows you to filter your search results by carbon emissions.

### 8. Get picky about your tour operator

Try to use companies that ensure local communities benefit from tourism in the region and that cultural and environmental conservation are prioritised.

### 9. Eat like a local

Eating local foods while travelling means you tread more lightly by eliminating the distance food has to travel. It also supports the local farmers and economy.

### 10. Travel for the better

Recreational travel and responsible travel aren't mutually exclusive. When choosing your destination, consider travelling 'for the better' and taking active steps to give back. Research community-based tourism initiatives that are fighting Climate Change, and consider doing some voluntary work to help them.

## Consider joining a Car Club

Many urban areas now have well-established pay-per-trip car clubs. The clubs offer access to a vehicle without the need for you to own a car yourself. Most charge an annual membership (typically £20-60); you then just pay as you drive (depending on the vehicle it can be as little as £3-4 per hour). More than 300,000 people, across the UK, are now regular users.

Car clubs can be a cheaper alternative to a second vehicle. The cars, on average, emit 43% less carbon dioxide as they tend to be newer, and are often electric.

Some clubs are run by local people; others are operated by some of the big vehicle hire businesses. Enterprise operates a club from its Gloucester depot in Bristol Road. There's also a community run club in the Stroud Valleys. Find out more from this website – [www.como.org.uk](http://www.como.org.uk)

# RECYCLING & WASTE

Each year Gloucestershire households produce nearly 300,000 tonnes of waste. Businesses produce even more, around 375,000 tonnes.

Then there's the waste from building sites, farms, used cars, electrical equipment, hospitals and so on. While it's easy to think of waste as someone else's problem this is not the case. We all generate waste, and we have a collective responsibility to do something about it.

On average every person in Gloucestershire generates more than a tonne of waste each year. A growing proportion of this is being

recycled, but a massive amount still ends up as landfill or is incinerated.

Hopefully you already do a good job of sorting your waste, and recycling as much as you can. But some things are trickier to recycle, so this Guide aims to help you identify a wide range of items that you can recycle, and explains where/how you can do this.

## Where to drop off difficult-to-recycle stuff

Batteries	Tesco, Brockworth Aldi, Hucclecote Road Churchdown Parish Council car park, Parton Road
Clothes	Tesco, Brockworth Churchdown Parish Council car park, Parton Road Churchdown Chapel Hay car park, Church Road
Shoes	Tesco, Brockworth Churchdown Parish Council car park, Parton Road
Lightbulbs	Churchdown Parish Council car park, Parton Road
Ink Cartridges	Tesco, Brockworth <a href="https://cartridges4charity.co.uk/">https://cartridges4charity.co.uk/</a>
Mobile phones	CeX, 34 Kings Square, Gloucester
Pill packets	Superdrug, Kings walk, Gloucester
Soft Plastics	Tesco Brockworth
Plastic film/cling film	Sainsburys Barnwood
Furniture	The Furniture Recycling project, 108 Eastern Avenue Gloucester

Note – these were correct at the time we went to press. Please use the websites listed on the next page to check.

## Useful Websites:

[www.gloucestershirerecycles.com](http://www.gloucestershirerecycles.com)

This website is managed by Gloucestershire County Council. It includes a 'waste wizard' facility that allows you to key in your postcode and search for the nearest place to dispose of a whole range of items – from coat hangers and mattresses, to cling film, disposable nappies, engine oil and e-cigarettes. It also has a database of charity shops and the items they are willing to take (eg books, furniture, clothes etc)



[www.lovefoodhatewaste.com](http://www.lovefoodhatewaste.com)

This is run by the Waste and Resources Action Programme (WRAP), which is a registered charity. The website provides tips on reducing food waste – the UK produces 36 million tonnes of greenhouse gas emissions from all the food that we currently bin. It is full of clever recipes, and helpful hints, tips and guidance to help you get the greatest value from your food, making sure it's eaten and saved from the bin.

[www.recyclenow.com](http://www.recyclenow.com)

The site has a searchable database for how and where to recycle individual items.

[www.terracycle.com/en-GB](http://www.terracycle.com/en-GB)

This website helps you 'recycle the unrecyclable'.

## Other Recycling Ideas:

**Facebook Marketplace:** List your unwanted items - someone may be able to find a use for something you no longer need. There is no need to charge for everything.

**CeX** is a second-hand electronics and games specialist where you can buy, sell and exchange games, phones, DVD's, Blu-rays, consoles, laptops, tablets, computers, electronics and gadgets for cash. There's a local outlet in Kings Square, Gloucester. <https://uk.webbuy.com/site/about/>

**ITSA** is based in Cheltenham, and will take old computer equipment and re-condition it for use in schools in Africa. [www.itschoolsafrica.org](http://www.itschoolsafrica.org)

**Donate to a local jumble sale, attend a car boot or table-top sale.** Again, finding someone else who can find a use for your unwanted items makes everyone happy.

**Local charity shops** will take items that are in re-saleable condition. Some will take electricals, but not all. Take care not to overburden them with items that they will not be able to sell though.

**Repair Cafe** – if an item is repaired, it becomes useful again; and doesn't end up in landfill. There are already regular Repair Cafes operating in Churchdown and Brockworth. Information about these and others locally can be found here <https://www.gloucestershirerecycles.com/reduce/repair/repair-cafes/>





### Lobbying retailers

If you feel items you buy at supermarkets or other shops have too much packaging, tell the store manager, or write to the company and ask them to reduce the packaging that goes to waste. If more people complain retailers will be forced to take action to reduce waste.

### New bins

Hucclecote Parish Council will be installing several new bins across the parish this summer – including a few that encourage passers-by to pre-sort their litter into either ‘Recyclables’ or ‘General Waste’. Please set an example to others and encourage them to drop their litter in the right receptacle.



### Litter picking sessions

Hucclecote is really fortunate in having a very active litter picking group – the fabulous Hucclecote Wombles. The group regularly ‘blitzes’ areas where there has been lots of litter dropped. If you want to join the group check out its Facebook page.

On Monday 8 May the Wombles will be organising a parish-wide litter picking session. See pages 16/17, or just pitch up a Pineholt Village Hall in Bird Road at 10am.

If you, your school or a group of neighbours would like to do some voluntary litter picking in your area, Tewkesbury Borough Council can help by providing litter picking tools and high visibility waistcoats. The council will also provide litter collection bags and it can also arrange for the litter to be disposed of after the event. Contact [litterpickers@tewkesbury.gov.uk](mailto:litterpickers@tewkesbury.gov.uk) or call 01684 272364.



# I SHOP LOCAL

I SUPPORT INDEPENDENT ARTISTS & CRAFTERS

# I INVEST IN MY COMMUNITY

I ENJOY GETTING TO KNOW MY NEIGHBOURS

# I LIKE TO REPAIR, RECYCLE OR REUSE

# I EAT FRESH

I CHOOSE QUALITY OVER QUANTITY

# I LOVE MY LOCAL ARTISANS

# I FIND VALUE IN THE COST

I WORRY ABOUT OUR FUTURE GENERATIONS

# I’M SAVING THE ENVIRONMENT

# I VISIT THE FARM MARKET

# I LOVE HANDMADE

# I’M PROUD TO KEEP OUR LOCAL ECONOMY GOING STRONG

# BUY LOCAL

Directory of local growers/makers and trades people



Name	Telephone/address	Website	Speciality
<b>GROWERS</b>			
Primrose Vale Farm Shop	01452 863359 Shurdington Road GL51 4UA	www.primrosevale.com	Wide range of veg, meats and fruit
Portway Farm Shop	01452 613255 Upton St Leonards GL4 8DP	www.portwayfarmshop.com	Butchers and coffee shop
Pound Farm Shop	01452 523936 Stroud Rd, GL4 0UG	www.poundfarmshop.co.uk	Cakes, pies and potatoes, plus veg and dairy
Over Farm Market	01452 341510 Over, GL2 8DB	www.overfarm.co.uk	Local meats, homemade treats, fresh fruit and veg
Gloucester M5 Services Farmshop	01539 624511 GL4 0DN	www.gloucesterservices.com/farmshop	Butchers, veg, cheese and fish counters and deli
Bisley Lane Farm	01452 770651 Edgeworth GL6 7JE	www.bisleylanefarm.com	Free range pork, beef, lamb and wild venison
Crooked End Farm	01594 544482 Drybrook, GL17 9XF	www.facebook.com/crookedendfarm?locale=en_GB	Fruit and veg boxes delivered to Hucclecote for £1
The Gloucester Honey Co	01452 547992 Chiltern Road, GL2 4TU	www.facebook.com/GlosHoneyCo/	Honey and beeswax
BS Honey	01452 645635 Hucclecote Lane, Churchdown, GL3 2LP	www.bshoneybees.co.uk	Honey, honey comb and bulk honey
Bushel & Peck	07710 777661 Bleby House Abbey Terrace, Winchcombe, GL54 5LL	www.bushelpeck.co.uk	Cider and Perry makers
<b>GARDEN CENTRES &amp; NURSERIES</b>			
Dundrys	01452 713124 Bamfurlong Lane, GL51 6SL	www.dundrynurseries.co.uk	Good range of veg seeds and young plants. Great selection of seed potatoes
Brockworth Garden Centre	01452 862334 Shurdington Rd, GL3 4PU	https://britishgardencentres.com/brockworth-garden-centre/	General garden centre with excellent pond/aquatic range
Shurdington Nurseries	01242 863738 Whitelands Lane, Little Shurdington, GL51 4TX	www.shurdingtonnurseries.co.uk	Good range of soil, compost, horse manure, sedum and wildflower mats

Name	Telephone/address	Website	Speciality
<b>GARDEN TOOLS</b>			
Mowers Online / Cheltenham Mowers Ltd	01452 616169 Unit B3, Nexus Court, Gloucester Business Park, GL3 4AG	www.mowers-online	Wide range of garden machinery, repairs, and accessories
<b>CYCLING</b>			
Slam 69	01452 690641 Unit 2, Pegasus Centre, Gloucester Business Park, GL3 4FF	www.slam69	Independent bike shop and workshop
<b>APPLIANCE REPAIRS</b>			
Gillmans	01452 509050 St Oswalds Rd, GL1 2SG	www.gillmans.co.uk	Servicing most domestic appliance brands
Stephens Electrics	01452 412225 Stephens Electric,s 2 Wellington Street, GL1 1RA	www.stephenselectrics.com	Washing machine repairs
Grants Sewing machines repairs	07702 290017 7 Burleigh Croft, Hucclecote GL3 3DP	www.facebook.com/profile.php?id=100039441226118	
<b>FURNITURE RECYCLING</b>			
Furniture recycling project	01425 302303 108 Eastern Avenue GL4 4LP	www.frgglos.org.uk	Charity that reuses items that would otherwise be sent to landfill
Vision 21	01452 712260 3 Brookfield Road, Churchdown GL3 2PQ	www.vision21.org.uk	Cheltenham based organisation that runs repair cafes, furniture recycling and more
<b>BAKERS/CAKES</b>			
The Village Cakery	01452 712260 3 Brookfield Road, Churchdown GL3 2PQ	www.the-villagecakery.co.uk	Amazing cakes and coffees - from slices to bespoke wedding cakes
Candeeebox	01452 864908 6-7 The Parade, Court Road, Brockworth, GL3 4EW	www.candeeebox.com	Sweets and cakes

Name	Telephone/address	Website	Speciality
<b>CRAFTS</b>			
Gloucestershire Guild of Craftsmen	07562 51654518 Rotunda Terrace, Montpellier Street, Cheltenham, GL50 1SW	<a href="https://shop.guildcrafts.org.uk">https://shop.guildcrafts.org.uk</a>	Features work by many of the county's top crafts people and designers
<b>POTTERY</b>			
Taena	01452 610908 Whitley Court Upton St. Leonards GL4 8EB	<a href="http://www.taenapottery.co.uk">www.taenapottery.co.uk</a>	Wide range of hand-thrown, slip-decorated domestic earthenware
<b>UPHOLSTERY</b>			
David Bourne	01452 617772 29 Hucclecote Road GL3 3TH		
Ians' Upholstery	07948141176 1 Church Road, Churchdown GL3 2ER	<a href="http://www.iansupholstery.co.uk">www.iansupholstery.co.uk</a>	
<b>ARTISTS</b>			
Scott Lethbridge Portraits	07852 956050 109 Chosen Way, GL3 3B	<a href="http://www.scottlethbridge.co.uk">www.scottlethbridge.co.uk</a>	Portraits drawn in graphite
Kd53 Digital Art	07905 612536 23 Arlington Rd, GL3 4GB	<a href="http://www.facebook.com/kd53dart/">www.facebook.com/kd53dart/</a>	Bespoke artworks based on animals and family pets
Paintings 4 you	07584 042881 188 Reservoir Road, GL4 6SB	<a href="http://www.petportraits.business.site/#summary">www.petportraits.business.site/#summary</a>	Dog, cat, horse or other pet portraits
Caroline Hope	07802184103 Court Farm, Little Witcombe GL3 4TU	<a href="http://www.facebook.com/carotheartist/">www.facebook.com/carotheartist/</a>	Wide range of paintings – many of local countryside scenes
<b>ECO SHOPS</b>			
The Green Shop	01452 770629 Calf Way, Bisley, GL6 7BX	<a href="http://www.greenshopgroup.co.uk">www.greenshopgroup.co.uk</a>	Eco friendly store stocking everything from food to paint and cleaning products
Food Loose	01242 894700 15 Grosvenor Terrace Cheltenham GL52 2SA	<a href="http://www.foodloose.co.uk">www.foodloose.co.uk</a>	Refill shop run by volunteers, with a focus on organic and sustainable produce
<b>SKINCARE</b>			
Field Fresh	61 High St, Cam, GL11 5LD	<a href="http://www.fieldfreshskincare.co.uk">www.fieldfreshskincare.co.uk</a>	Fresh, natural skincare using local ingredients
<b>CHIMNEY SWEEP</b>			
J Bird	07973 905151 74, Swift Road, Abbeydale, GL4 4XH	<a href="mailto:SOOTYBLOKE@blueyonder.co.uk">SOOTYBLOKE@blueyonder.co.uk</a>	
<b>ENERGY SUPPLIER</b>			
Ecotricity	01453 488101 Lion House, Rowcroft, Stroud, GL5 3BY	<a href="http://www.ecotricity.co.uk/our-story">www.ecotricity.co.uk/our-story</a>	Locally based green energy

Name	Telephone/address	Website	Speciality
<b>GREEN TECHNOLOGIES</b>			
Green Shop Solar	01452 772030 Calf Way, Bisley, GL6 7BX	<a href="http://www.greenshopsolar.co.uk">www.greenshopsolar.co.uk</a>	PV, batteries, installation service and maintenance
Solr	01452 915 341 Unit 3 Capitol Park, Pearce Way, GL2 5YD	<a href="http://www.solr.co.uk">www.solr.co.uk</a>	Gloucester based solar panel and battery installer
Rain Harvesting Systems	01452 772000 Calf Way, Bisley, GL6 7BX	<a href="http://www.rainharvesting.co.uk">www.rainharvesting.co.uk</a>	Leading rainwater harvesting company
ARD solar energy	01452 506801 4 Harvest Way, Gloucester, GL2 4YU	<a href="http://www.ardsolarenergy.co.uk/index.htm">www.ardsolarenergy.co.uk/index.htm</a>	Gloucester based solar panel and battery installer
Redbridge & Sons	01452 203 121 Unit 11 The Glenmore Centre, Jessops Ave, Gloucester GL2 2AP	<a href="http://www.redbridgeandsons.co.uk/about-us">www.redbridgeandsons.co.uk/about-us</a>	Solar, battery and air source heat pump installer
Roxon Electrical	01452 731088 Unit D4 Innsworth Technology Park GL3 1DL	<a href="http://www.roxonelectrical.co.uk">www.roxonelectrical.co.uk</a>	Innsworth based solar panel and battery installer
Ecomirage	01452346357 Unit 2 Spillmans Court, Middle Spillmans, Rodborough, GL5 3RU	<a href="http://www.ecomirage.co.uk/about">www.ecomirage.co.uk/about</a>	Solar panels, battery and heat storage
Forever Green Energy	01242 395 120 Unit C, Churchill Rd, Cheltenham GL53 7EG	<a href="http://www.forevergreen-energy.co.uk">www.forevergreen-energy.co.uk</a>	Cheltenham based solar panel and battery installer
Rendesco	01242 698410 Cherrington Chambers 14 Rodney Road, Cheltenham, GL50 1JJ	<a href="http://www.rendesco.com">www.rendesco.com</a>	Heat pump design, installation and maintenance
HPR	01452 379 807 Unit 6B, Tuffley Park, Lower Tuffley Lane, Gloucester GL2 5DE	<a href="http://www.hprservicesltd.com/renewables/ground-source-heat-pumps/">www.hprservicesltd.com/renewables/ground-source-heat-pumps/</a>	Ground and air source heat pump installer
Cotswold Energy Group	0333 444 5 444 1 Upper Mills, Stonehouse, Gloucestershire GL10 2BJ	<a href="http://www.cotswold.energy">www.cotswold.energy</a>	Ground and air source heat pump installer
ISO Energy	01293 827 702 Unit 4, The Hidings, Love Lane Industrial Estate, Cirencester, GL7 1YG	<a href="http://www.isoenergy.co.uk/about-us">www.isoenergy.co.uk/about-us</a>	Design and installation of ecologically sustainable, solar and heat pump systems



# LAND USE - PROTECTING THE BEST OF THE AREA FROM FURTHER DEVELOPMENT

We have undertaken a survey of green areas and other important community spaces in the parish.

The five main areas we feel could be protected from further development by getting them designated as community assets are:

- The public open space that surrounds Pineholt Village Hall, the new sports facilities, and the Wootton Brook corridor (1)
- Hucclecote Meadows SSSI (2)
- The Horsbere Brook Nature Reserve (3)
- The public open space that fronts onto Guan Road/Digby Grove, on the Coopers Edge development (4)
- The wooded area on top of Chosen Hill (5)

The last two may require us to co-operate with Upton St Leonards and Churchdown Parish Councils as the sites are either partially or wholly in their areas.

There are five excellent guided walks available on the Parish Council website – [www.hucclecotepc.gov.uk](http://www.hucclecotepc.gov.uk) – just click on the ‘Galleries’ section. We are lucky to be close to some wonderful Green Belt land, and the Cotswold Area of Outstanding Natural Beauty.

If you are passionate about our patch why not offer to do some volunteering – see page 9. You might also want to consider becoming a Parish Councillor. Just pop into the parish office to find out more.

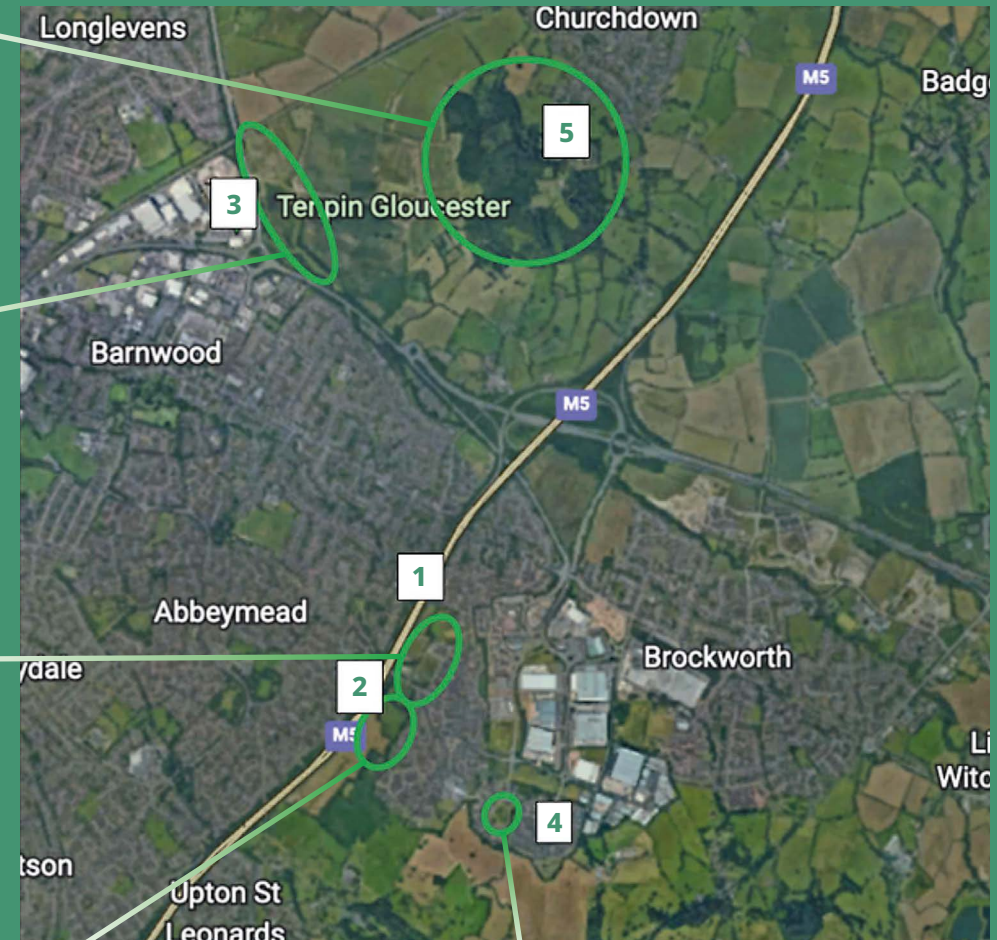



# MAKE A DIFFERENCE MAKE A PLEDGE, OR TWO...

Take some practical steps towards making a difference by ticking as many of the ten pledges below as you think you can achieve

- I pledge to explore how I can reduce the plastic and other waste I generate.
- I pledge to buy local, seasonal produce as much as possible
- I pledge to educate myself about the science of Climate Change, and the impact it is having
- I pledge to walk, cycle, use public transport or organise lift sharing as I travel to work (or undertake another regular journey) at least one day a week
- I pledge to work out my own carbon footprint using one of the many easy to use calculators, such as [www.footprint.wwf.org.uk](http://www.footprint.wwf.org.uk)
- I pledge to find out what things I can do to make my home more energy efficient.
- I pledge to explore turning my thermostat down to reach the lowest comfortable setting (typically between 18-21°C), and to wear a jumper or thicker underwear instead.
- I pledge to reduce my holiday air miles by 50%
- I pledge to make my garden more pollinator-friendly by, for example, installing a bird box/insect hotel and/or planting some wildflowers
- I pledge to contact my current electricity supplier to see if I can switch to renewable energy (and if they can't offer this, I'll move to a supplier who can)

We are grateful to HATS,  
which has sponsored  
the production of the  
Green Guide

**HUCCLECOTE ACCOUNTING  
& TAXATION SERVICES**

The parish office is at  
**Pineholt Village Hall,  
Bird Road, GL3 3SN**

Tel: 01452 612485

Email: [hucclecotepc@supanet.com](mailto:hucclecotepc@supanet.com)  
(the office is open weekday mornings)

